

# ESKA

[www.eskavalve.com](http://www.eskavalve.com)

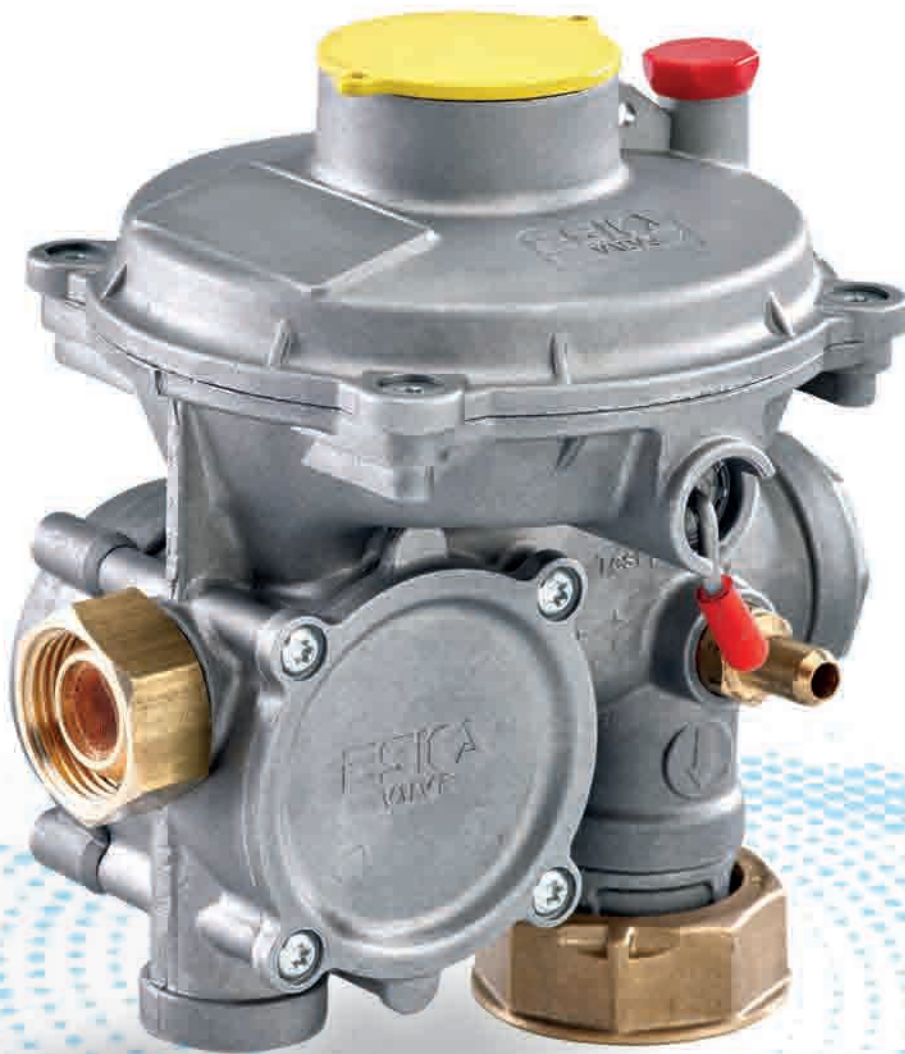

**ERG-S**  
**SERIES**

ERG-S Series double stage pressure regulator is used on gas line to reduce inlet pressure to desired outlet pressure. It is suitable for both commercial and domestic usage where can be directly installed to gas meters with high operational reliability and accurate outlet pressure accuracy.

Simple installation procedure.

Due to different inlet and outlet connection range, ERG-S Series can be used along with pipe diameter from DN15 to DN50 with different thread standards as well as BSP, BSPT, NPT, NPP.

The modular concept of ERG-S and wide range availability of inlet and outlet connections allow to match particular customer requirements.

The regulators are manufactured according to **Ped Directive 2014/68/EU**. The functional tests are performed according to **EN334**.

## FEATURES

- For medium pressure domestic or commercial second group gas lines.
- Optional metallic mesh filter for easy change and guarantees longer operation life of regulator.
- Outlet pressure tolerance is +%10 (AC10) up +- %5 (AC5)
- Lock-up pressure tolerance is +%20 (SG20) up to 100 mbar outlet pressure, more than 100 mbar outlet pressure SG20 and SG10 possible.
- Up to 6 bar inlet pressure.
- 18 - 500 mbar outlet pressure range with interchangeable springs

### Optional ;

- Incorporated Under Pressure Shut Off Valve.
- Internal Relief Valve

## DIMENSIONS

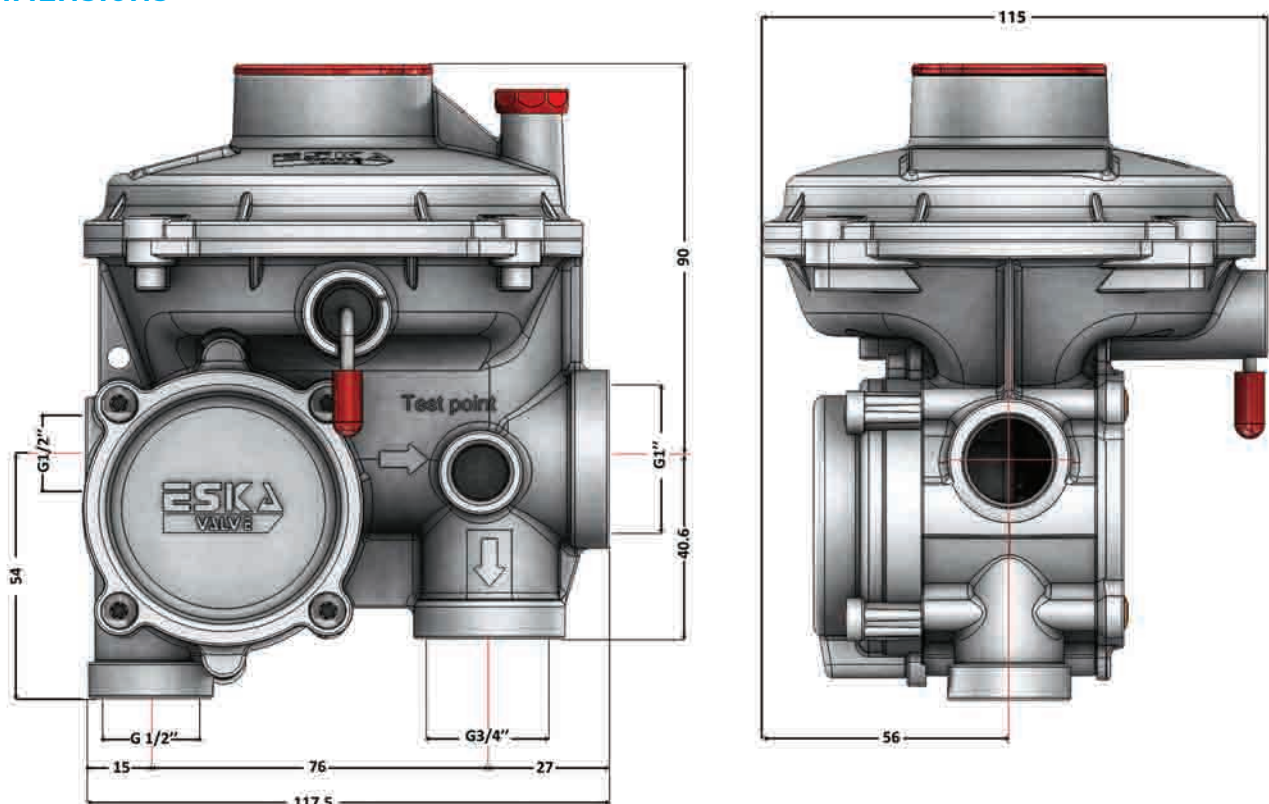

**CONNECTION TYPES**

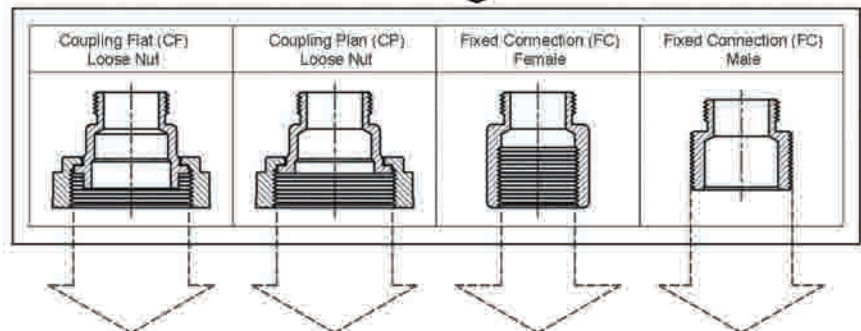
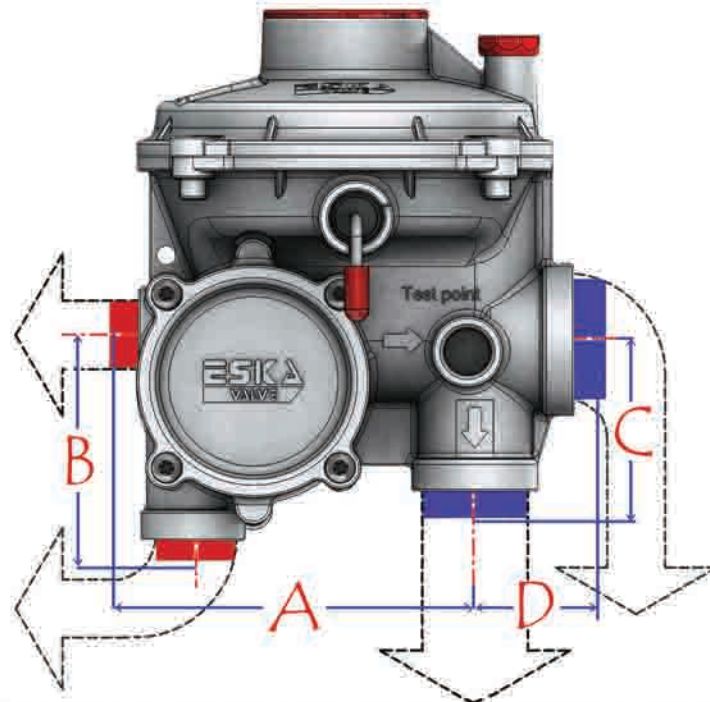
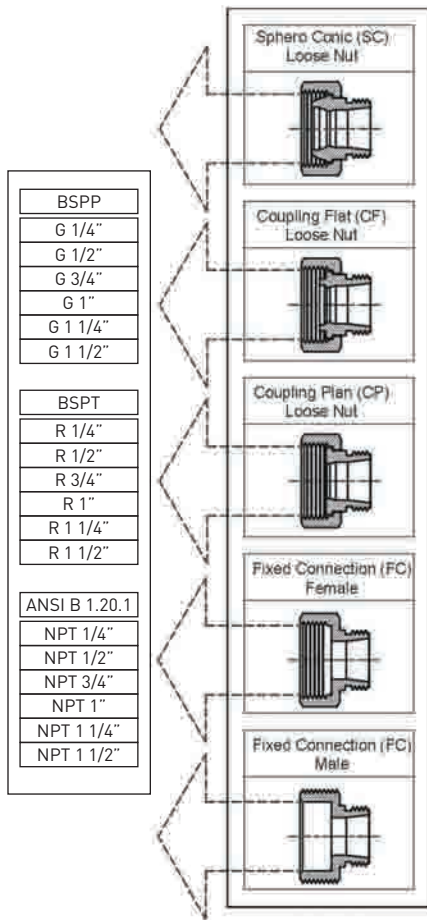

BSPP	BSPT	ANSI B 1.20.1
G 1/4"	R 1/4"	NPT 1/4"
G 1/2"	R 1/2"	NPT 1/2"
G 3/4"	R 3/4"	NPT 3/4"
G 1"	R 1"	NPT 1"
G 1 1/4"	R 1 1/4"	NPT 1 1/4"
G 1 1/2"	R 1 1/2"	NPT 1 1/2"

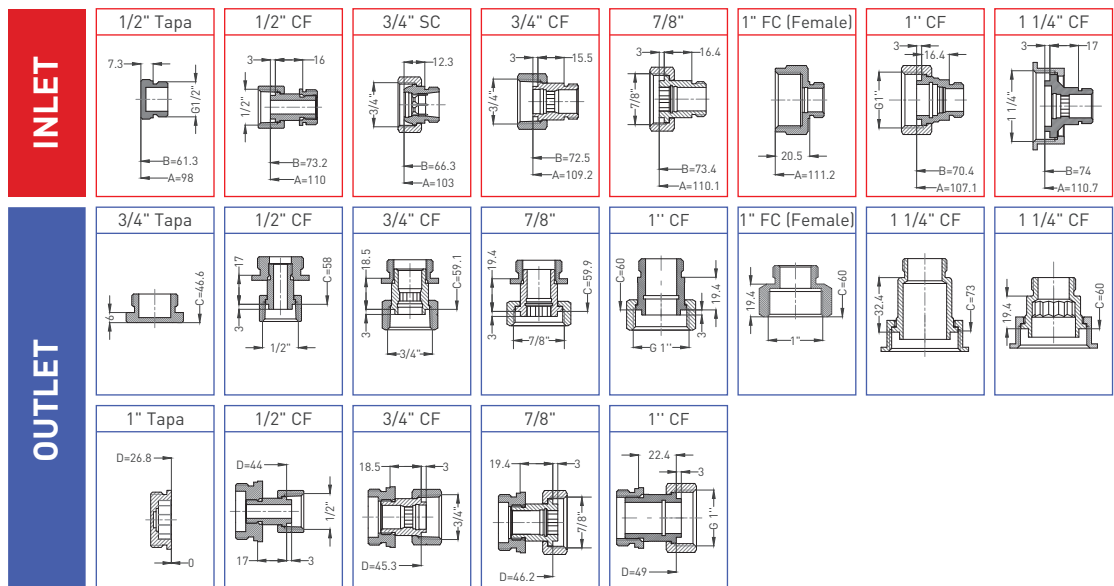

**SAFETY AND ACCESSORIES**

**Relief System**

Regulator can be produced with a relief valve. Relief valve monitors outlet pressure continuously and when it detects pressure level higher than regulator's nominal outlet pressure, it activates and discharges gas to the atmosphere.

Relief valve has limited discharge capacity. Usually calibration point is lower than OPSO system. Under certain conditions such as gas expansion during hot weather seasons, Relief Valve is activated before OPSO closes the gas lines. It prevents random shut-off regarding pressure increase on outlet side.

Relief valve can be recalibrated by using proper tools.

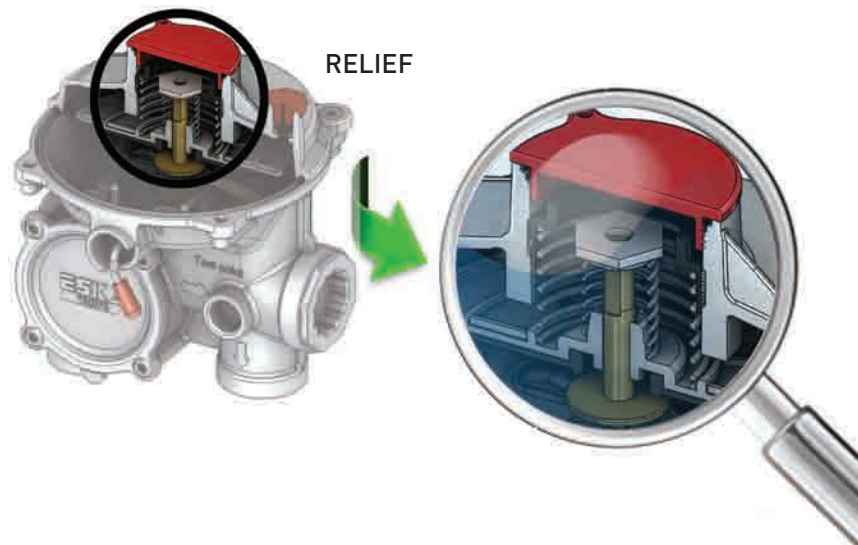

**Under Pressure Shut-Off System.**

UPSO system on ERG- S series regulator acts under those circumstances;

- When there is no pressure inlet side.
- When the consumption exceed regulator's maximum capacity. ( $101\%Q$  to  $150\%Q$ )
- When the pressure drop outlet side due to consumption.

UPSO valve continuously monitors outlet pressure changes. Scenarios like, pipeline breakdown on outlet sides, or consumption is exceeding the total capacity of regulator or lack of inlet pressure situations etc...the outlet pressure drops and the regulator cuts the gas off once UPSO system is activated.

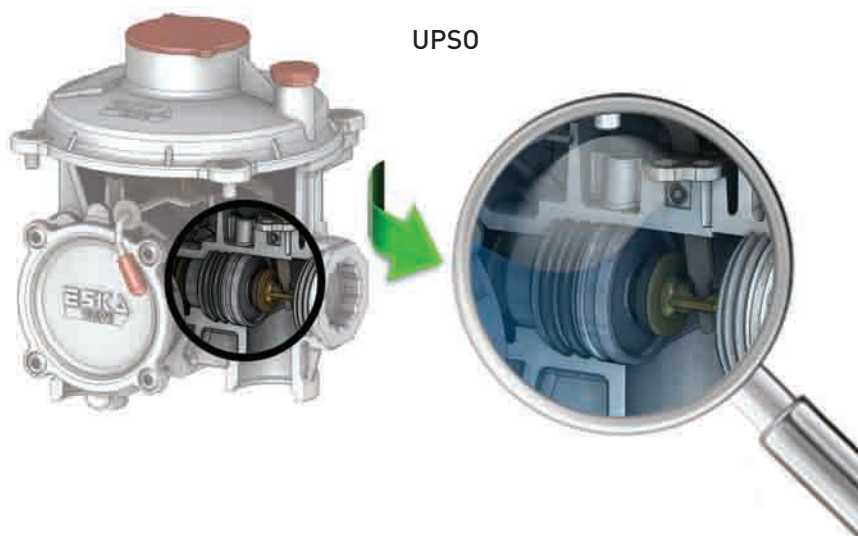

## CONFIGURATIONS

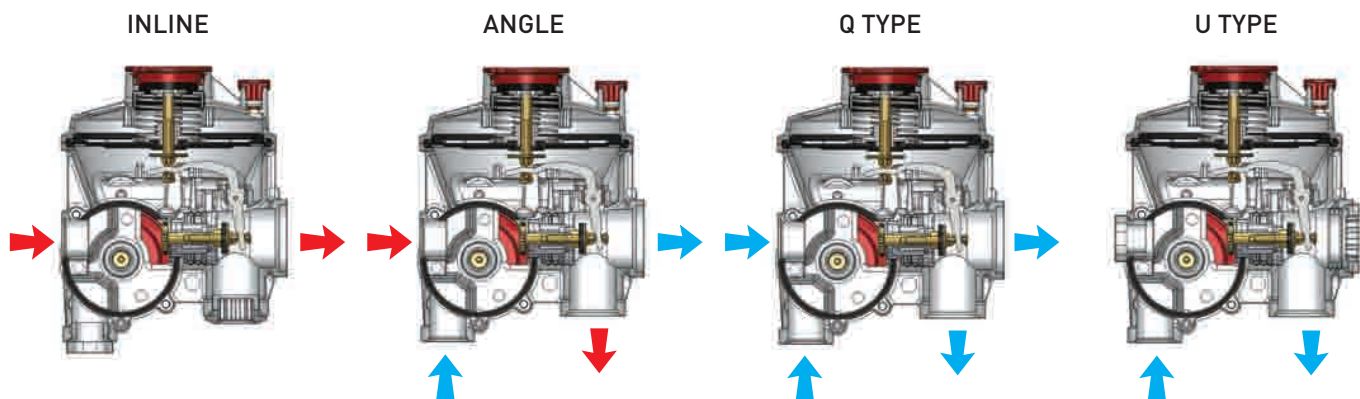

## SPECIFICATIONS

Medium	: Natural Gas, LPG and Non-Corrosive Gases
Operating temperature	: -20... + 60°C (optional : -40... +60°C)
Assembly	: Vertical and Horizontal Position
Maximum inlet pressure	: 6 bar
Minimum inlet pressure	: Depending on customer request can start as low as 0,1 bar.
Outlet pressure range	: 18 to 500 mbar.
Filter	: Included

## DESIGN

The ERG-S Series pressure regulator body may consists of:

- Valve housing
- Connections
- Filter
- Ventilation console
- Outlet pressure test point
- Integrated security valves (UPSO / Relief)

## MATERIALS

- Body and covers Aluminum according to EN1706 standard.
- Rubber components are Nitril Rubber comply to EN 549.
- Brass materials are suitable according to EN12164 - EN12165 Standard.
- Filter material is metallic mesh filter.

## MODELS

MODEL	FLOW RATE			UNIT WEIGHT (kgs)	BOX SIZE (LxWxH cm)	PACKAGING (pieces/ carton)	CARTON SIZE (LxWxH cm)	CARTON (weight)	TOTAL CARTON (weight)
	LPO 18-75 mbar	MPO 75-150 mbar	HPO 150-500 mbar						
ERG-S 06	6			1,10	15x14.5x16	16	33x58x35	0.65kg	18.2 kg
ERG-S 10	10			1,10	15x14.5x16	16	33x58x35	0.65kg	18.2 kg
ERG-S 25	25			1,10	15x14.5x16	16	33x58x35	0.65kg	18.2 kg
ERG-S 50	50			1,10	15x14.5x16	16	33x58x35	0.65kg	18.2 kg

BESIDE STANDARD FLOW RATES ABOVE, 1,6 / 2,5 / 15 / 30 / 40 / 60 / 65 SCMH ARE AVAILABLE UPON REQUEST.